



TIME INTERVAL JITTER METER KJM6765/6755A

DVD/CD compatible. Supports a clock frequency
of 4.1 MHz to 60MHz (KJM6765)

DVD compatible. Supports a clock frequency
of 25 MHz to 150MHz (KJM6755A)

*De facto standard.
Now even more advanced.*

PHASE MON

POWER

 KIKUSUI

TIME INTERVAL JITTER METER

TIME INTERVAL JITTER METER **KJM6765/6755A**

Trailblazer

Excellent cost-performance

Standard off-the-shelf DVD jitter meter, KJM6755A

The DVD Specifications for Read-Only Discs Ver. 1.0, Aug. 1996 (hereafter referred to as the DVD Book) specify the jitter measurement method as follows: Time differences between all edges of an RF signal and a clock signal generated from the RF signal are measured to obtain their variation (α value) as jitter. The KJM6755A is a DVD jitter meter that employs the time interval method, a measurement method compliant with the DVD Book. Its specialized circuits for jitter measurement enable it to achieve significant cost reduction, as well as jitter measurement by inputting RF signals only in addition to conventional TIA-based two-signal (DATA to CLOCK) tests. Moreover, the PLL clock regeneration circuit, equalizer circuit, and slicer circuit are compliant with the DVD Book. Since its release, the KJM6755A has been acknowledged as the de facto standard for jitter measurement in DVD players thanks to its excellent cost-performance.

Also capable of measuring jitter in CD players,
as first introduced in the industry!*

Jitter measurement using the time interval method, KJM6765

The KJM6765 employs the time interval method for measuring jitter in CD players as well as in DVD players, based on principles successfully used in the KJM6755A. The frequency response characteristics of the symmetry follow-up circuit, PLL clock regeneration circuit, and equalizer circuit in the DVD mode comply with the DVD Book, while those of the symmetry follow-up circuit and PLL clock regeneration circuit in the CD mode adhere to the Compact Disc Reference Measuring Methods Specification Guideline Ver. 1.0, May 1999.

Moreover, the KJM6765 has an INHIBIT INPUT terminal, enabling it to measure jitter during track jumps or with the index part of the DVD or CD masked.

With the advent of multi-disc players, standardization of the measurement principle for jitter in CD players and DVD players contributes to productivity improvements and reduction in equipment costs. And above all else, it ensures the reliability of measurement results.

* As of Feb. 15, 2000



KJM6765



KJM6755A

Panel Description

The time interval method
DVD/CD Jitter meter

KJM6765

- Enables time-interval-based measurement of jitter in DVD/CD players
- Supports a clock frequency of 4.1 MHz to 60 MHz
- Equipped with an INHIBIT INPUT terminal as standard
- Incorporates a memory (4 addresses) for presetting the panel settings
- An I/O port has been added for handshaking with an external evaluation unit or jigs
- Equipped with GPIB interface (models with GPIB interface only)

front view



rear view

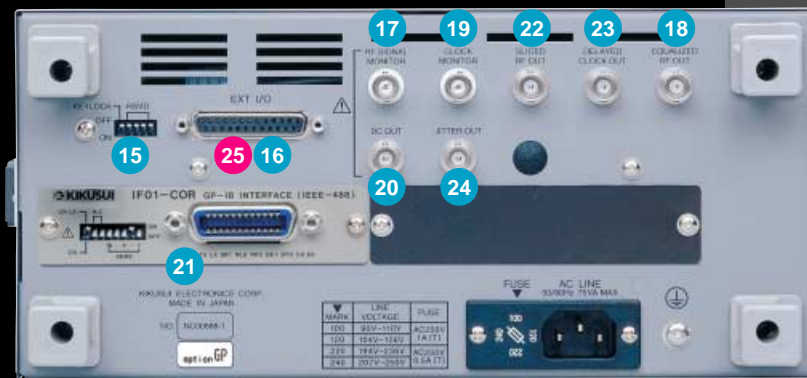

1 PHASE MONITOR

Displays the phase difference between RF and clock signals, and the distribution of jitter. At the far left of the monitor, 0° phase difference is indicated, and at the far right of the monitor, 360° phase difference is indicated. The frequency distribution of jitter and the average phase difference between RF and clock signals can be seen at a glance; this phase monitor increases the efficiency of operations such as the bottom adjustment of pickups. For example, for pickups that have not yet been adjusted, the frequency distribution of jitter becomes wide, causing the LED indication to be spread out over the entire monitor screen. Pickups that have been adjusted, on the other hand, it has a narrow frequency distribution of jitter, which causes the LED indication to be concentrated in the center of the monitor screen and to appear sharp.

- Normal jitter measurement condition (phase difference of 180°)
- When an input signal with distribution peaks at two locations is input
- When the phase difference is 0°, resulting in incorrect measurement

2 METER

This meter indicates a jitter value (standard deviation value). The % indication shows a jitter value in percentage to one clock cycle when one clock cycle is regarded as 100%. KJM6765: Deals with clock signals of 4.1MHz - 60MHz seamlessly. The ns indication shows a jitter value for the absolute value of time. KJM6755A: Deals with clock signals of 15 - 150MHz seamlessly. The ns indication shows a jitter value at 27MHz clock. (only valid when clock frequency is 27MHz)

3 MEMORY / RECALL key (KJM6765 only)

A maximum of four types of instrument panel settings can be stored in the setup memory for later recall.

4 MEDIA key (KJM6765 only)

Selecting the media (CD / DVD-ROM) for measurement.

5 DELAY key

Selecting the delay mode. In the AUTO mode, the delay time is automatically controlled to maintain the average phase difference between RF and clock signals at 180°. In the MANUAL mode, the delay time must be adjusted using the DELAY-TIME-setting variable register.

6 PLL and EQ keys

Allows the PLL clock regeneration circuit or equalizer circuit to be turned on/off with a single touch

7 TRIGGER EDGE key selector key for clock signal

Possible to change the trigger edge of a clock signal. Each time the key is pressed, the trigger edge is switched to the rising or falling edge.

8 TRIGGER EDGE key selector key for RF signal

The switch to change the trigger edge of an RF signal. Can be selected from among three types: rising edge, both edges, and falling edge.

9 Input IMPEDANCE key

Allows the input impedance to be changed to 50Ω or 1 MΩ, to suit a jig, FET probe, or other device

10 METER SCALE key

KJM6765: 10%, 20%, 1.5ns, 5ns, 15ns, 50ns
KJM6755A: 10% / 3ns, 20% / 6ns

11 JUDGE key

The GO LED lights up when a measured value is smaller than a judgment-level set value, while the NO GO LED lights up when it is larger than that value. The judgment result is output at the TTL level, or through the GPIB interface.

12 TIME CONST key

The switch to select a time constant for conversion to an rms value. The time constant can be selected from among 0.03 s, 0.1 s, 0.3 s, and 1 s.

TIME INTERVAL JITTER METER KJM6765/6755A

13 SYMMETRY key

This switch is used to select the operation mode of the symmetry circuit, and the variable resistor for level setting. The operation mode can be selected from among three: AUTO, AUTO+OFFSET, and MANUAL.

[Operations in AUTO]

This jitter meter is equipped with a function that enables the slice level to automatically track the symmetry level of an RF signal, in order to correct asymmetry in the RF signal. This is achieved by performing feedback control of the slice level, so that DC values obtained after the RF signal is sliced become 0.

[Operations in AUTO+OFFSET]

In this mode, an offset function can be added to the slice level.

[Operations in MANUAL]

In this mode, the slice level does not respond to the symmetry level of an RF signal. When an RF signal that has already been binarized using a jig or other means is measured, always set the operation mode to MANUAL. The slice level can be set using the slice-level-setting variable resistor.

14 INHIBIT key (KJM6765 only)

Used for on/off setting and switch the polarity of the inhibit function.

15 KEY LOCK switch

When this switch is set in the direction indicated by the arrow, the keys on the front panel will be locked. (KJM6765 provides the dip switch.)

16 JUDGE OUT terminal

Outputs the judgment results for GO/NO GO at the TTL level. The judgment result is GO when a signal is at a high level, and NO GO when it is at a low level. (KJM6765 has judge output terminal on the EXT I/O connector.)

17 RF SIGNAL MONITOR terminal

This terminal is used to monitor RF signals, and outputs an amplitude approximately 1/10 of the input amplitude. It is also used in calibration of the probe.

18 EQUALIZED RF OUT terminal

Outputs an RF signal that has passed through the equalizer when EQ is ON.

19 CLOCK MONITOR terminal

This terminal is used to monitor clock signals, and outputs an amplitude approximately 1/10 of the input amplitude. It is also used in calibration of the probe.

20 DC OUT terminal

Outputs the voltage proportional to a measured value (0.2 V/%). The output impedance is approximately 600 Ω.

21 GPIB interface

This is a 24-pin connector in compliance with the IEEE 488-1978 GPIB Standard.

* This is available only for the models with the GPIB feature.

22 SLICED RF OUT terminal

Outputs an RF signal that has been sliced by the slicer circuit. The output amplitude is 0.2 V to 0.3 V p-p.

23 DELAYED CLOCK OUT terminal

Outputs a clock signal with a phase difference to an RF signal that has been adjusted by the delay circuit. The output amplitude is 0.2 V to 0.3 V p-p.

24 JITTER OUT terminal

Outputs the waveform of jitter sampled prior to conversion into a root-mean-square value (rms).

25 EXT I/O connector (KJM6765 only)

External control connector (D-sub 25 pins)

The time interval method
DVD Jitter meter



KJM6755A

- Enables time-interval-based measurement of jitter in DVD players
- Supports a clock frequency of 25 MHz to 150 MHz
- Excellent cost-performance
- Equipped with GPIB interface (models with GPIB interface only)

front view



rear view

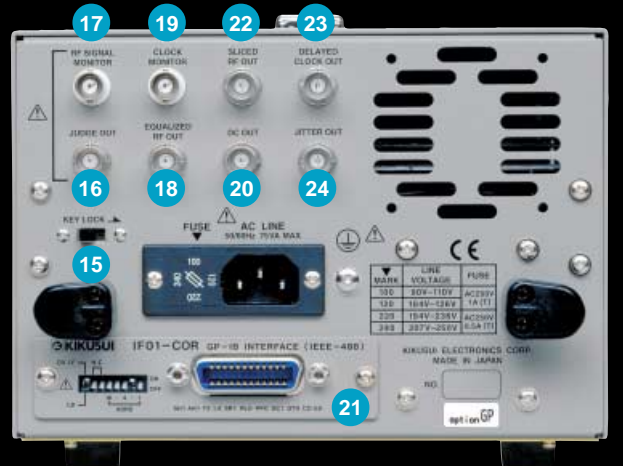

Functions

Supporting

DVD

Conform to the DVD Book!!

Conforming to the DVD Specifications for Read-Only Disc Ver. 1.0, Aug. 1996

CD

Supporting CD Measuring Methods!!

Conforming to the Compact Disc Reference Measuring Methods Specification Guideline Ver.1.0, May. 1999

Note: Available for KJM6765 only.

- For determination of the evaluation criteria for DVD discs
- For adjustment and evaluation of the tilt in pickups
- For determination of the evaluation criteria for OEM supplies
- For reduction of the cycle time in player production lines
- For comparison with semiconductors
- For signal evaluation of servo systems
- For substitution for jigs
- For development of RF-based units in which measurements cannot be made by TIA
- For the necessity of checking players promptly
- Optimum for service stations

KJM6765 / 6755A supports the following five measurement methods.

1. Measurement of an RF1 signal from an optical pickup

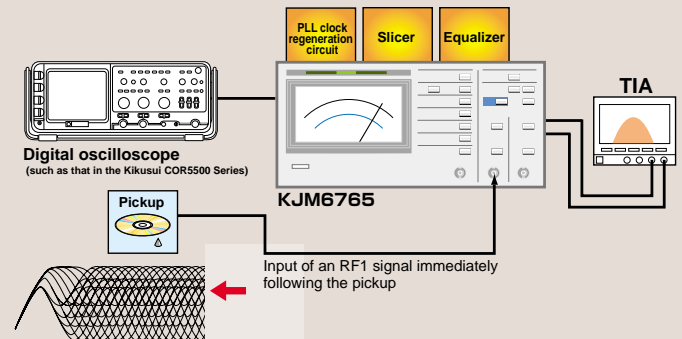

- The KJM6765/6755A has a terminal on its rear that outputs an RF signal that has passed through the equalizer circuit compliant with the DVD Specifications for read-only disc Ver. 1.0, Aug. 1996 (DVD Book). This allows an equalized RF signal to be monitored using an oscilloscope.
- The KJM6765/6755A has a terminal on its rear that outputs an input RF signal; RF signals sampled immediately following the pickup can be checked.
- From its rear panel, the KJM6765/6755A outputs a binarized signal that has passed through the equalizer, PLL clock frequency, and slicer circuits, and also outputs a clock signal that has passed through the delay circuit to adjust the phase difference to 180° degrees relative to the RF signal. This allows the signals on TIA (time Interval Analyzer) to be checked together with the jitter meter. This feature is very useful in checking the correlation between the jitter meter and TIA on production lines and at other locations.

In the past, carrying out measurements using a time interval analyzer (TIA) required a clock signal and binarized RF signal from a DVD player or a jig. Now, however, measurements can be taken simply by connecting TIA to the terminals on the rear of the KJM6755A. The KJM6755A is equipped with an equalizer, a PLL clock regeneration circuit, and slicer circuit as standard, and this made KJM6755A compliant with the DVD Specifications for read-only-disc Ver 1.0, Aug. 1996. As a result, it actually has the response characteristics specified in the DVD Book as measurement criteria. KJM6755A is now widely accepted as the de facto standard in the DVD marketplace. Presently, the measurement of jitter in DVD pickups is represented in the specifications, often including the characteristics of both the optical pickups and the equalizer. However, because the KJM6755A equalizer complies with the DVD Book, the characteristics of the optics and the equalizer are evaluated separately. The jitter meter is very useful when, for example, determining the evaluation criteria for each model of DVD pickups or reviewing the pickups of each manufacturer on an OEM basis. Moreover, when it is urgently necessary to evaluate a system, having a KJM6755A on hand allows jitter measurements to be carried out easily using an RF signal. In general, RF signals cannot directly be measured on TIA.

Moreover, the KJM6765 is equipped with a PLL clock regeneration circuit, and slicer circuit as standard which comply to Compact Disc Reference Measuring Methods Specification Guideline Ver. 1.0 May 1999.

TIME INTERVAL JITTER METER KJM6765/6755A



2. Measurement of an RF signal from an optical pickup that has passed through an equalizer

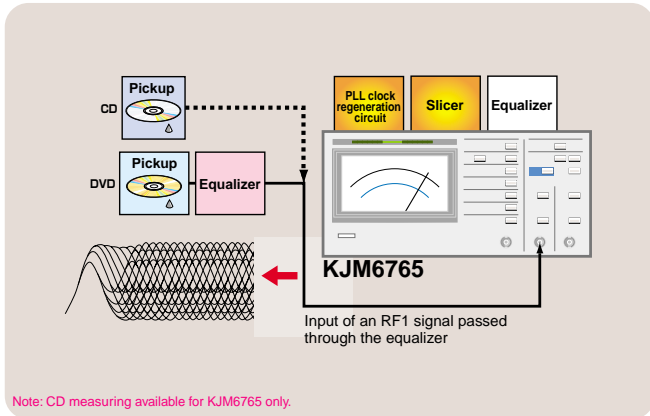

In tilt adjustment for DVD pickups or players, an equalizer adjusted to the characteristics of the optics is often used. On production lines, such an equalizer can be installed on the jig side, enabling the sampled signal to be input to the jitter meter. A comparison between the results obtained in (1) and those obtained in (2) reveals the differences between the characteristics of jitter sampled by the DVD-Book-based equalizer and those sampled by the equalizer on the system side.

4. Measurement in compliance with the DVD Book

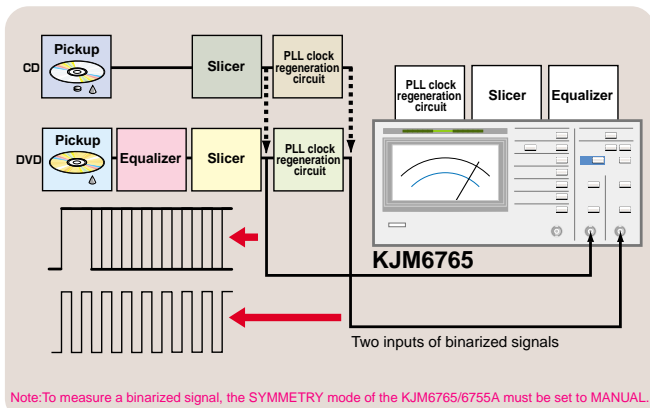

For the DVD Book-specified measurement method, this procedure replaces the time-interval analyzer with a KJM6765/6755A. An RF signal after the slicer and a clock signal are input to the KJM6765/6755A for measurement.

3. Measurement using a binarized signal following use of a slicer

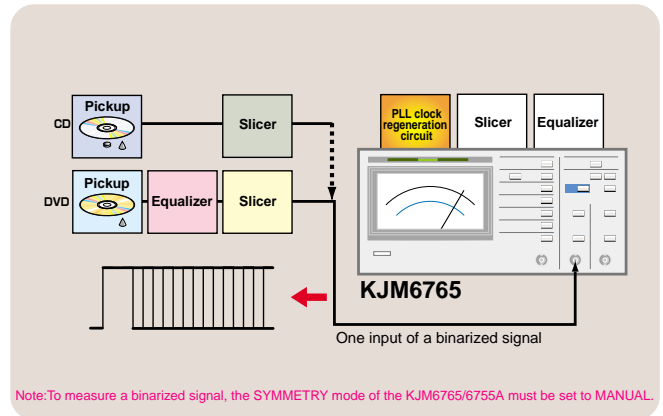

This method uses only the PLL clock regeneration circuit built into the KJM6765/6755A. In some semiconductors, a regenerated PLL clock signal is not output externally, but is directly fed back to a servo system. In such cases, the significant power of KJM6765/6755A's internal PLL clock regeneration circuit becomes crucial. For example, in the evaluation of discs, the base on the drive side must be maintained in a certain condition. In such a case, the PLL clock regeneration circuit's compliance with the DVD Book and CD Measuring Methods provides an advantage.

5. Supporting a wide range of clock signal

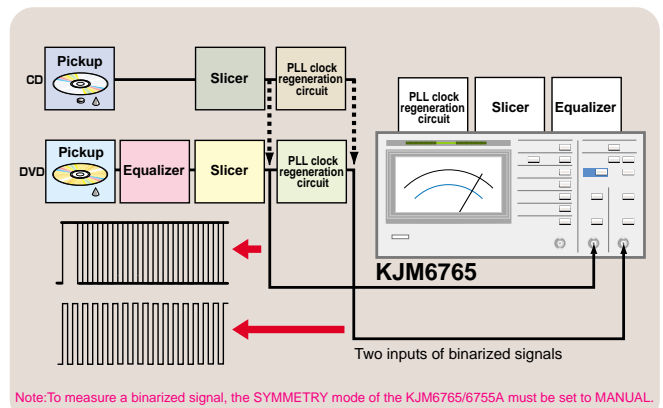

The KJM6765/6755A can cover the wide range of clock signal for future development of 1.5 to 2 times higher speed of Players.

- KJM67654.1MHz to 60MHz
- KJM6755A25MHz to 150MHz

SPECIFICATIONS

		KJM6765	KJM6755A
■Input			
Number of input channels		3 (RF, CLOCK, INHIBIT)	2 (RF, CLOCK)
RF input	Input signal	EFM signal, 8-16 modulating signal, Minimum pulse width 15ns	8-16 modulating signal, Minimum pulse width 15ns
CLOCK input	Input signal	clock frequency CD: 4.1MHz to 25MHz DVD:25MHz to 60MHz Duty ratio within 45:55 to 50:50	clock frequency DVD:25MHz to 150MHz Duty ratio within 45:55 to 50:50
	Signal voltage range	0.2 to 2Vp-p	
	Input impedance	1MΩ (18pF ± 3pF) ,50Ω	
	Maximum input voltage	4Vpeak (DC + AC)	
	Input connector	BNC	
INHIBIT input	Input level	High level: 4.0 to 5.0V, Low level: 0 to 1.0V	
	Minimum inhibit period	500μs	
	Maximum inhibit time (in measurement of a single signal)	15ms (at an inhibit period of 20 ms or more)	
		75% of inhibit period (at an inhibit period of 1ms to 20ms)	
		Inhibit period -250μs (at an inhibit period of 500μs to 1ms)	
	Maximum inhibit time (in measurement of two signal)	10ms (at an inhibit period of 13.3ms or more)	
		75% of inhibit period (at an inhibit period of 1ms to 13.3ms)	
		Inhibit period -250μs (at an inhibit period of 500μs to 1ms)	
Maximum input voltage	10Vpeak (DC + AC)		
■Measurement			
Measurement range		0 to 20%, 0 to 50ns	0 to 20%
Specification guaranteed range	% indication	2 to 15%	2 to 15% (clock frequency: 25MHz to 60MHz) 5 to 15% (clock frequency: 60MHz to 150MHz)
	ns indication	2% to 15% of clock period	—
Measurement accuracy	% indication	±5% of full scale of the meter	
	ns indication	±2% of clock period + ±2% of meter's maximum value on scale	—
Residual jitter	% indication	2% or less	1% or less (clock frequency: 25MHz to 60MHz) 2% or less (clock frequency: 60MHz to 150MHz)
	ns indication	2% of clock period or less	—
Time constant for conversion into an rms value		30ms, 100ms, 300ms, 1s	
■Indication			
Indicator		Analog meter	
Unit		%, ns (Unit ns of KJM6755A is for supplemental scale at 27MHz clock.)	
Scale (FS)		10%, 20%, 1.5ns, 5ns, 15ns, 50ns	10%, 20%, 3ns, 6ns (Full scale: 10%, 20%, 3.7ns, 7.4ns)
GO or NO GO judgment		Two LEDs, red (NO GO) and green (GO), indication	
PHASE MONITOR		Indicates the phase difference between the RF signal and clock signals and the distribution of jitter. The distribution of jitter frequency is indicated by the brightness on the meter.	
■Trigger			
Symmetry follow-up *1		AUTO, AUTO + OFFSET, MANUAL	
Trigger edge	RF	Rising edge, falling edge, both edges	
	CLOCK	Rising edge, falling edge	
Delay circuit		Clock signal is delayed to adjust the phase of an input signal. AUTO/MANUAL selection Phase adjusting range in MANUAL mode: 0 to 360°	
■Equalizer circuit *2			
Frequency characteristics		5.16MHz: +3.2 ± 0.3dB (amplitude ratio as reference is 10kHz) 10.3MHz: -2.8 ± 1.0dB (amplitude ratio as reference is 10kHz)	
Group delay frequency characteristics		Mximum group delay deviation ≤ 6ns (range: 0.7MHz ≤ f ≤ 6.7MHz)	
■PLL clock regeneration circuit *3			
CD normal speed mode	Synchronizing available signal	EFM signal that channel clock is equivalent to 4.1MHz to 4.5MHz	
	Frequency response characteristics	1kHz: 0.2 ± 1.7dB (amplitude ratio as reference is 100kHz)	
		5kHz: -0.1 ± 1.7dB (amplitude ratio as reference is 100kHz)	
		10kHz: -0.9 ± 1.7dB (amplitude ratio as reference is 100kHz)	
		20kHz: -3.1 ± 1.7dB (amplitude ratio as reference is 100kHz)	
25kHz: -4.2 ± 1.7dB (amplitude ratio as reference is 100kHz)			
DVD normal speed mode	Synchronizing available signal	8-16 modulated signal that channel clock is equivalent to 25MHz to 30MHz	
	Frequency response characteristics	1kHz: 0.2 ± 1.7dB (amplitude ratio as reference is 100kHz)	
		3kHz: 1.3± 1.7dB (amplitude ratio as reference is 100kHz)	
		7kHz: 1.0 ± 1.7dB (amplitude ratio as reference is 100kHz)	
		15kHz: -4.0 ± 1.7dB (amplitude ratio as reference is 100kHz)	
15kHz: -4.0 ± 1.7dB (amplitude ratio as reference is 100kHz)			
Both mode common	Lockup time	700ms or less	
	Synchronizing available jitter range	5% to 17%	
	Residual jitter	0.7% or less	

SPECIFICATIONS

		KJM6765	KJM6755A
■Output (Rear)			
RF MONITOR	Output amplitude	Approx. 1/10 (terminated with 50Ω) of input amplitude	
	Output impedance	Approx. 50Ω	
CLOCK MONITOR	Output amplitude	Approx. 1/10 (terminated with 50Ω) of input amplitude	
	Output impedance	Approx. 50Ω	
SLICED RF OUT	Output amplitude	Approx. 0.2V to 0.3V (terminated with 50Ω)	
	Output impedance	Approx. 50Ω	
DELAYED CLOCK OUT	Output amplitude	Approx. 0.2V to 0.3V (terminated with 50Ω)	
	Output impedance	Approx. 50Ω	
EQUALIZED RF OUT *4	Output amplitude	Approx. 0.2V to 0.3V (sine wave input with 4MHz, terminated with 50Ω)	
	Output impedance	Approx. 50Ω	
DC OUT	Output amplitude	0.2V/%, accuracy of ± 0.15V	
	Output impedance	Approx. 600Ω	
JITTER OUT	Output amplitude	Approx. 20mV/%	
	Output impedance	Approx. 600Ω	
JUDGE OUT	Output logic	Available in EXT I/O Interface	H: GO, L: NOGO, TTL level
EXT I/O Interface		Four-bit parallel input/output port	/
		External recall input of setup memory address	
		Output of setup memory address number	
		Within measuring-range output	
		Judge out	
GPIB interface *5		Complies with IEEE Std. 488-1978. SH1, AH1, T6, L4, SR1, RL1, PP0, DC1, DT0, C0, E1 Operated in address mode. Allows user to set and read each feature on the front panel.	
■Environmental conditions / General Specifications			
Warm-up time		Approx. 30 minutes	
Storage temperature and humidity ranges		Temperature: -20°C to 70°C, Humidity: 90% or less R.H. (no condensation)	
Operating temperature and humidity ranges		Temperature: 0°C to 40°C, Humidity: 20% to 85% R.H. (no condensation)	
Specification guaranteed temperature and humidity ranges		Temperature: 15°C to 35°C, Humidity: 20% to 85% R.H. (no condensation)	
Allowable range of supplied voltage		90V to 110V / 104V to 126V / 194V to 236V / 207V to 250V AC	
Allowable power frequency range		45Hz to 65Hz	
Maximum power consumption		75VA	
Insulation resistance		50MΩ or more (500V DC)	
Withstand voltage		1500V AC for one minute	
EMC		Complied with the following standards European Community Requirements (89/336/EEC) EN55011 Radiated Emissions class A Conducted Emissions class A EN50082-1 IEC801-2 Electro-static Discharge IEC801-3 Radiated Susceptibility IEC801-4 Fast Burst Transient	
Safety	—	Complied with the following standards European Community Requirements (73/23/EEC)	
Dimensions(mm)		Approx. 280(W)×132(H)×270(D) Maximum: Approx. 300(W)×150(H)×320(D)	Approx. 200(W)×140(H)×270(D) Maximum: Approx. 210(W)×170(H)×310(D)
Weight		Approx. 5.5kg	Approx. 5kg
Battery backup		Setup data is backed up.	
Accessories		Power cord: 1pc, Manual: 1 pc Fuses 90V to 110V / 104V to 126V :1A(T) 1pc, 0.5A(T) 2pcs *6 Fuses 194V to 236V / 207V to 250V :1A(T) 2pcs, 0.5A(T) 1pc *6	

*1 Response characteristics in AUTO mode

KJM6755A and KJM6765 DVD mode: Complies with DVD specifications for Read-Only Disc Ver. 1.0, Aug. 1996.

KJM6765 CD mode: Complies with Compact Disc Reference Measuring Methods Specification Guideline Ver. 1.0, May. 1999.

*2 This equalizer circuit is designed to handle an 8–16 modulating signal at a reference clock frequency of 27 MHz. Since the frequency response characteristics specified in the DVD Book are for a reference clock frequency of 26.16 MHz, the specifications are determined by converting a frequency of 26.16 MHz to 27 MHz, and by converting 5.0 MHz to 5.16 MHz and 10 MHz to 10.3 MHz. This circuit complies with the DVD specifications for Read-Only Disc Ver. 1.0, Aug. 1996.

*3 The frequency response characteristics are valid at a reference clock frequency of 27 MHz (DVD normal speed mode) and 4.3MHz (CD normal speed mode). The frequency response characteristics specified in the DVD Book are represented in the open-loop characteristics, while those of the KJM6755A and KJM6765 are controlled by the relevant closed-loop characteristics. The circuit complies with the DVD specifications for Read-Only Disc Ver. 1.0, Aug. 1996. Complies with Compact Disc Reference Measuring Methods Specification Guideline Ver. 1.0, May. 1999.

*4 The output amplitude is value at turning on the equalizer.

The KJM6755A and KJM6765 incorporates an AGC circuit in the input block to maintain a constant amplitude of the RF signal, passes the signal through the HPF circuit, and processes it in the equalizer and slicer (symmetry correction) circuits, in that order. This is done to maintain constant slicing (symmetry correction) characteristics, regardless of the input amplitude. Thus, the characteristics of the signal output from the EQUALIZED RF OUT terminal contain the characteristics of the AGC and HPF circuits, in addition to those of the equalizer specified in the DVD Book.

*5 Available only for the models with the GPIB feature

*6 A total of three fuses are provided with the instrument. The breakdown voltage of the fuses depends on the setting of the line voltage upon shipment from the at factory.

The fuse holder is equipped with

1A fuses for 90V to 110V / 110V to 126V or

0.5A fuses for 194V to 236V / 207V to 250V

for shipment.

ORDERING INFORMATION

Description	Model	Remarks
The time interval method	KJM6765	
DVD/CD Jitter meter	KJM6765 with GPIB	Equipped with GPIB Interface
The time interval method	KJM6755A	
DVD Jitter meter	KJM6755A with GPIB	Equipped with GPIB Interface



KIKUSUI ELECTRONICS CORP.

1-1-3, HIGASHIAMATA, TSUZUKI-KU, YOKOHAMA, 224-0023, JAPAN

TEL: (+81)45-593-7570, Fax: (+81)45-593-7571

Internet: <http://www.kikusui.co.jp/>

●Distributor:

■ All products contained in this catalogue are equipment and devices that are premised on use under the supervision of qualified personnel, and are not designed or produced for home-use or use by general consumers. ■ Specifications, design and so forth are subject to change without prior notice to improve the quality. ■ Product names and prices are subject to change and production may be discontinued when necessary. ■ Product names, company names and brand names contained in this catalogue represent the respective registered trade name or trade mark. ■ Colors, textures and so forth of photographs shown in this catalogue may differ from actual products due to a limited fidelity in printing. ■ Although every effort has been made to provide the information as accurate as possible for this catalogue, certain details have unavoidably been omitted due to limitations in space. ■ If you find any misprints or errors in this catalogue, it would be appreciated if you would inform us. ■ Please contact our distributors to confirm specifications, price, accessories or anything that may be unclear when placing an order or concluding a purchasing agreement.